

SWITCH PAD DETAIL GENERAL NOTES:

1. THE TOP 12" OF SUBGRADE BENEATH THE SLAB SHALL BE THOROUGHLY COMPACTED TO 90% OF MAXIMUM DENSITY PER ASTM D698. IF TOP 36" OF SUBGRADE IS SUBJECT TO HIGH WATER TABLE OR PERIODIC SATURATION, COMPACT SUBGRADE TO 90% PER ASTM D2039 AND D1556. NO FROZEN BACKFILL SHALL BE USED.
2. SLAB TO BE MADE OF FIBER REINFORCED POLYMER (FRP) CONCRETE WITH MINIMUM 28 DAY STRENGTH OF 3,500 PSI WITH 2 INCH LENGTH OF MONOFILAMENT MACROSYNTHETIC FIBERS AT APPROXIMATELY 4 LB/YD³ DOSAGE. ADD AIR-ENTRAINING ADMIXTURE CONFORMING TO ASTM C260/C260M.
3. TOP OF PAD TO BE SMOOTH, LEVEL AND CLEARED OF ALL FRAMING MATERIAL AFTER CONCRETE SETS.
4. NO WALLS SHALL BE BUILT AROUND PRIMARY SWITCH, NOR CANOPIES ABOVE SWITCH.
5. ALL CONDUIT ENTERING SLAB TO BE VERTICAL AND AT A 90° ANGLE WITH TOP OF SLAB. PROVIDE ALL SPARE CONDUITS WITH PULLSTRINGS & PLASTIC CAPS.
6. COORDINATE WITH UNL UTILITIES TO ALLOW ANY AND ALL INSPECTIONS BEFORE, DURING AND AFTER CONSTRUCTION OF PAD.
7. PAD SHALL BE LOCATED A MINIMUM OF 3' FROM ANY GAS METER AND A MINIMUM OF 10' FROM ANY FUEL TANK.
8. LOCATE PAD A MINIMUM OF 12" ABOVE THE 100 YEAR FLOOD PLAIN.

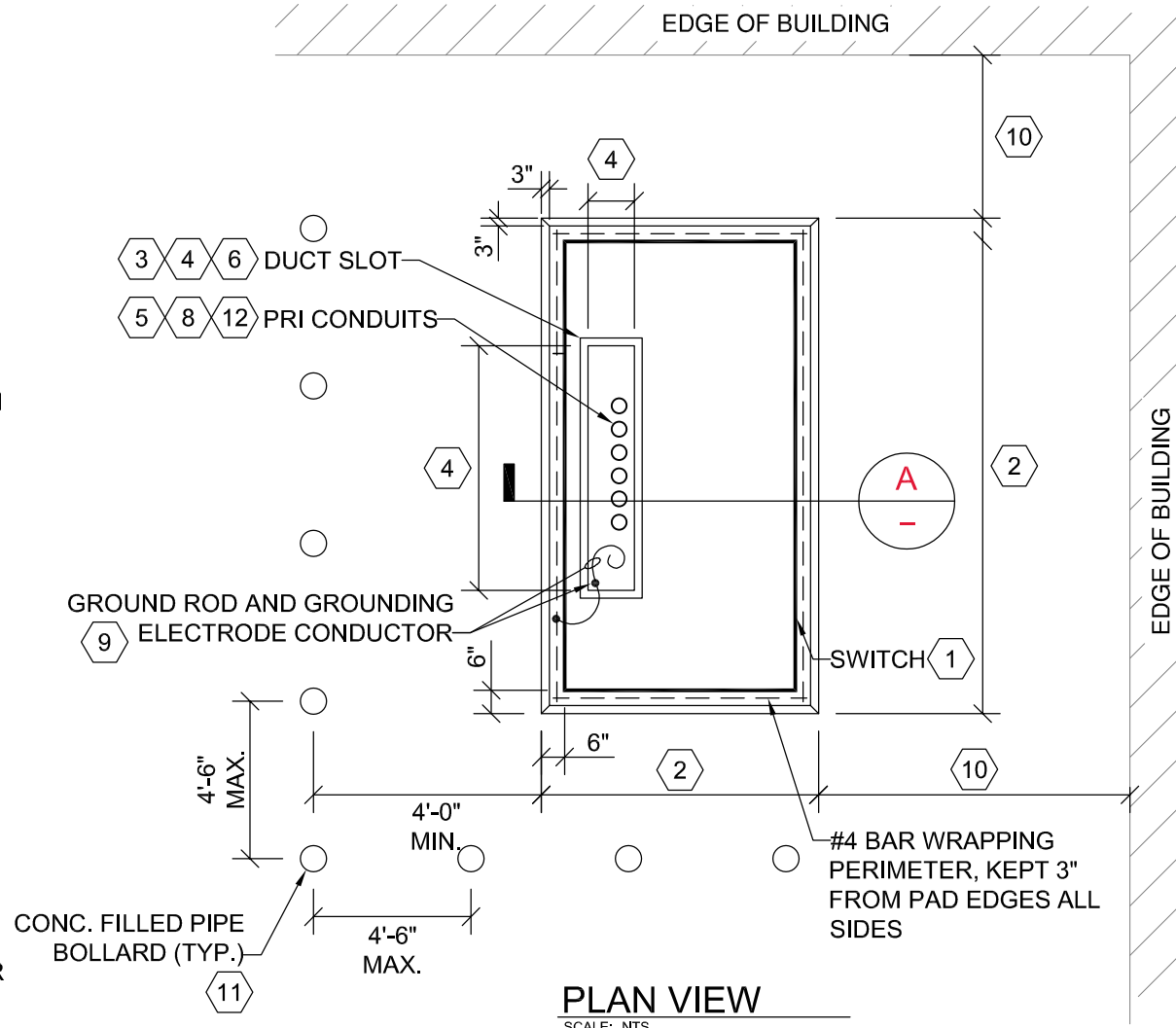

PLAN VIEW
SCALE: NTS

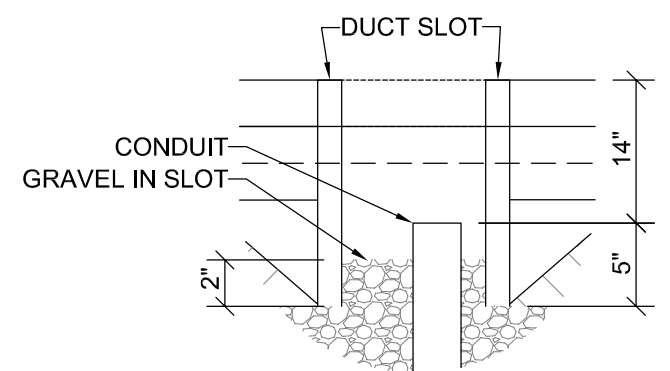

DUCT SLOT ENLARGED VIEW
SCALE: NTS

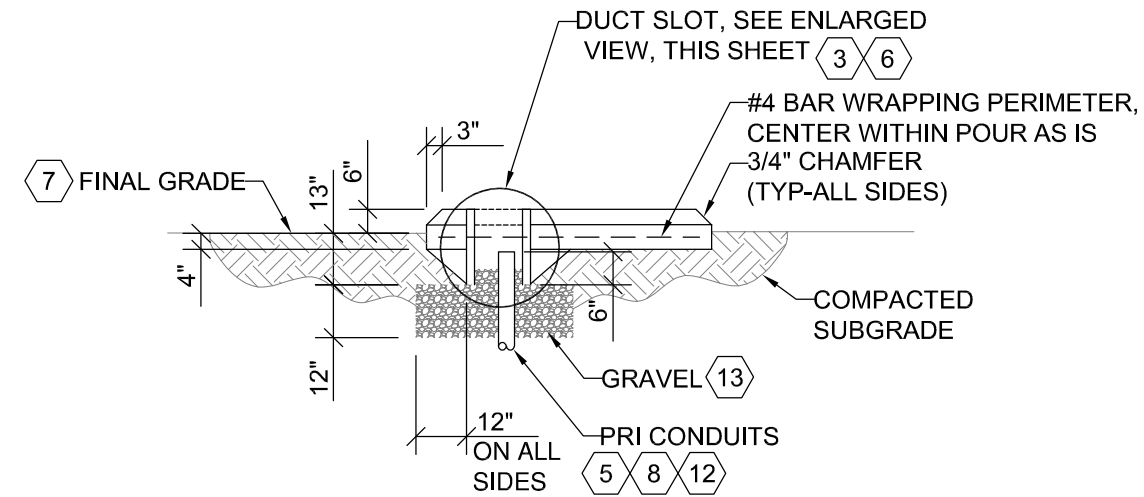

SECTION VIEW
SCALE: NTS

SWITCH PAD DETAIL KEY NOTES:

1. SWITCH FOOTPRINT TO BE CONFIRMED WITH UNL PRIOR TO PAD WORK.
2. IN ALL CASES SWITCH PAD SHALL EXTEND 6" BEYOND EDGE OF SWITCH ON ALL SIDES. THIS DISTANCE IS TO BE MEASURED FROM THE FURTHEST PROTRUDING PORTION OF THE SWITCH ON ANY GIVEN SIDE.
3. 24" DEEP DUCT SLOT CENTERED UNDER SWITCH CABLE OPENING. PROVIDE WITH 2" MIN. THICK WALLS AND ANGLED REINFORCING AS NECESSARY.
4. DUCT SLOT WIDTH AND LENGTH AS REQUIRED PER MANUFACTURER RECOMMENDATIONS AND TO ACCOMMODATE PROJECT CONDUIT QUANTITIES. NOMINAL WIDTH (LEFT-TO-RIGHT FACING THE SWITCH FRONT) TO BE EXTENDED TO WITHIN 4 INCHES OF SWITCH STRUCTURAL ANCHOR POSITIONS.
5. DUCTS ARE NOT TO BE INSTALLED IN CONCRETE WITHIN THE DUCT SLOT.
6. LOCATION AND DIMENSIONS OF DUCT SLOT AND CONDUITS WITHIN SLOT MUST BE MAINTAINED IN RELATION TO OVERALL SLAB DIMENSIONS.
7. FINAL GRADE AROUND PAD TO SLOPE AWAY FROM SWITCH PAD (ALL SIDES) AND FROM THE ADJACENT BUILDING EXTERIOR WALLS.
8. INSTALL CONDUITS IN DUCT SLOT TIGHT TO BACK OF DUCT SLOT AS MUCH AS POSSIBLE TO ALLOW SPACE FOR FUTURE DUCT INSTALLATION.
9. 5/8" X 10' COPPER CLAD GROUND ROD AND 20' OF #4 GEC STUB ROD FLUSH WITH TOP OF PAD. TIE REBAR IN POUR TO GROUND ROD WITH GEC AND CONNECT ALSO TO SWITCH TANK GROUND LUG. BOND USING UL LISTED MEANS.
10. MINIMUM OF 10' SHALL BE MAINTAINED BETWEEN PAD AND BUILDING EXTERIOR WALL WHERE WALL IS MADE OF COMBUSTIBLE MATERIAL. FOR NON-COMBUSTIBLE WALLS, PROVIDE 12" MINIMUM CLEARANCE BETWEEN PAD AND BUILDING. SWITCHES BELOW WINDOWS SHALL HAVE A MINIMUM 15' VERTICAL DISTANCE BETWEEN TOP OF TRANSFORMER AND BOTTOM OF WINDOW.
11. CONCRETE BOLLARDS WILL BE REQUIRED IF PAD IS WITHIN 6' OF AN AREA SUBJECT TO VEHICULAR TRAFFIC.
12. PROVIDE CONDUITS WITH MINIMUM 36" RADIUS SWEEPS. QUANTITY & SIZES OF CONDUITS PER PROJECT REQUIREMENTS. STUB CONDUITS UP 6" FROM BOTTOM OF DUCT SLOT.
13. PROVIDE CRUSHED ROCK AROUND BOTTOM OF DUCT SLOT, A MINIMUM OF 12" ON ALL SIDES. INCLUDE A 2" LAYER INSIDE DUCT SLOT SURROUNDING THE CONDUITS.
14. DETAILS ON THIS SHEET CAN NOT BE ALTERED WITHOUT WRITTEN CONSENT FROM THE CIVIL ENGINEER.