

KEY NOTES

1. SIDE STREAM BAG FILTER WITH BOLT-ON TOP, SIDE INLET, BOTTOM OUTLET, 30 MICRON SIZE BAGS. FILTER FLOW RATE SHALL BE SIZED BASE ON EIGHT (8) WATER SYSTEM VOLUME CHANGES PER DAY.
2. CHEMICAL POT FEEDER.
3. AIR/DIRT SEPARATOR, LINE SIZE. SPIROTHERM, NO EQUIVALENT.
4. PACKAGED GLYCOL FEED SYSTEM WITH: MIXING TANK, FEED PUMP, CHECK VALVES, ISOLATION VALVES, PRESSURE RELIEF VALVE, OVERFLOW CONNECTION, MANUAL CONTROLS.
5. BLADDER TYPE EXPANSION TANK.
6. PROVIDE 12" MINIMUM ANTI-CONVECTION TRAP TO PREVENT HEATING OF EXPANSION TANK.
7. PIPE OUTLET OF PRESSURE RELIEF VALVE TO GLYCOL FEED TANK.
8. CW FILL LINE WITH VALVE AND HOSE-BIBB.
9. AUTOMATIC ISOLATION VALVE PROVIDED BY UNL INSTALLED BY CONTRACTOR.
10. SPLIT DISK, WAFER STYLE CHECK VALVE.
11. VENTURI STYLE FLOW METER. GRISWOLD OR EQUAL.
12. 2" AND SMALLER STEEL PIPE TO BE SCHEDULE 80.

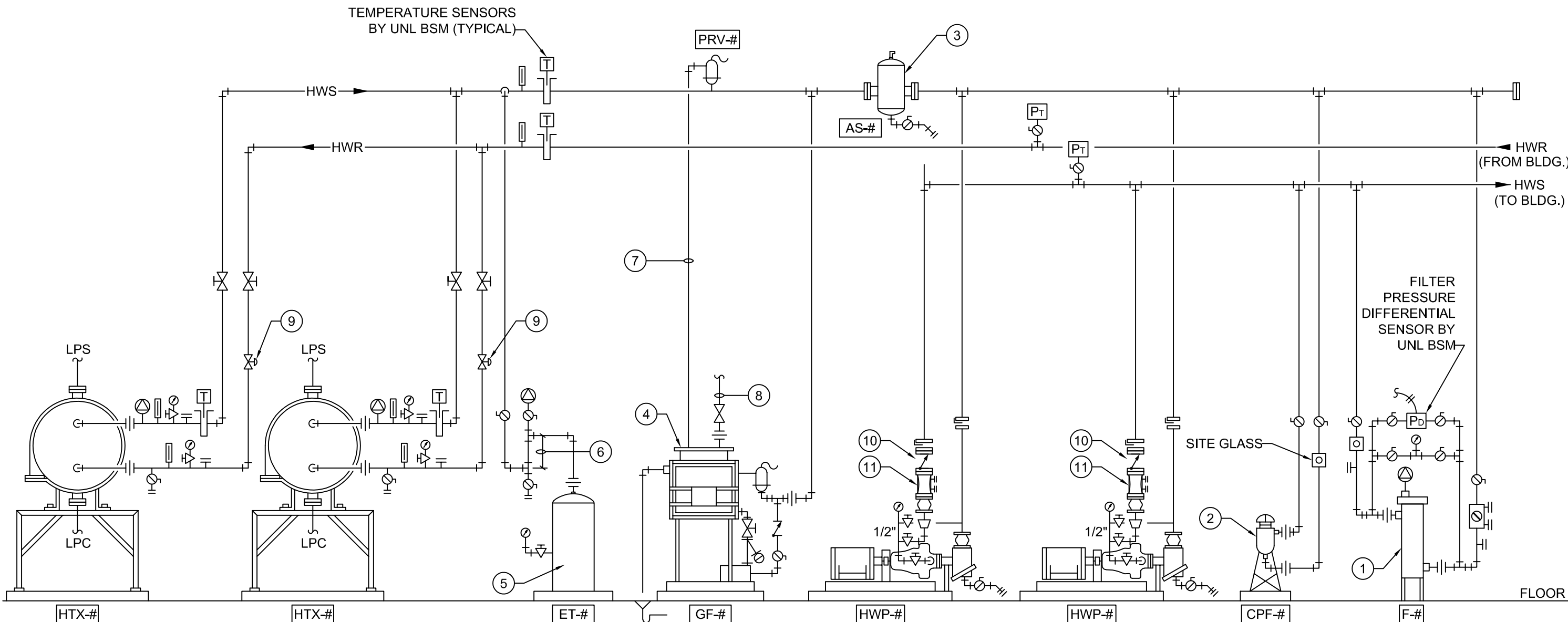
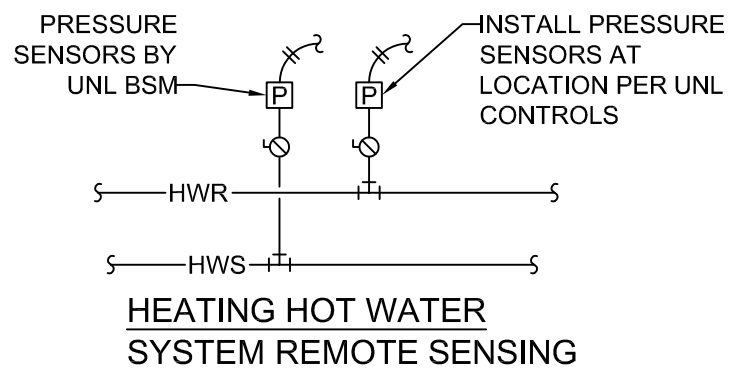

HEATING HOT WATER SYSTEM

PIPING SCHEMATIC

1
A1.01 SCALE: NO SCALE